

LOG-1

Blaze / Vega Serial Data Logger

Datasheet – English 1.01



Introduction

The LOG-1 is a datalogger for the Blaze and Vega range of instruments. Serial Information is received via the RS232 port and recorded to the SD card.

The data on the SD card is stored in a Comma Separated Values (.CSV) file that can easily be opened in a spreadsheet or text viewer type program.

The LOG-1 is housed in a space saving aluminum enclosure and is very easy to install.

1 Features

- Dual RS232 ports to log data from 2 Blaze or Vega instruments
- Data is stored in a Comma Separated Values file (.CSV) onto a SD card
- Supports all SD cards (Both normal and HC SD cards)
- 8-30VDC switch mode power supply with built in 33V over voltage and reverse voltage protection
- Extremely easy to install
- Space saving aluminium enclosure
- 1 Year Warranty

2 Specifications

SD Card	
Capacity	Normal and HC cards supported
Output file format	Comma Separated Values (.CSV)
Electrical	
Supply Voltage	8 to 30VDC switch mode power supply with built in 33V over voltage and reverse voltage protection
Supply Current	Typically 65mA @ 12Vdc
General	
Status LEDES	<p>Green LED Flashing: Receiving data Off: Receiving no data</p> <p>Orange LED Flashing: Logging to SD card Solid: SD card error / Write protect Off: Not logging to SD card</p> <p>Red LED Flashing: Power / SD card Present Solid: Power</p>
Serial Interface	2x RS232 ports
Weight	Approx. 140 grams without cables
Environmental:	
Operating temperature	-10°C to 50°C (14°F to 122°F)
Storage temperature	-40°C to 80°C (-40°F to 176°F)
Operating and storage humidity	<85% RH non-condensing
Enclosure:	
Enclosure Material	Anodized Aluminum with ABS plastic side plates
Enclosure Color	Black
Enclosure Dimensions	88mmx88mmx33mm (3.46"x3.46"x1.3")

3 Dimensions

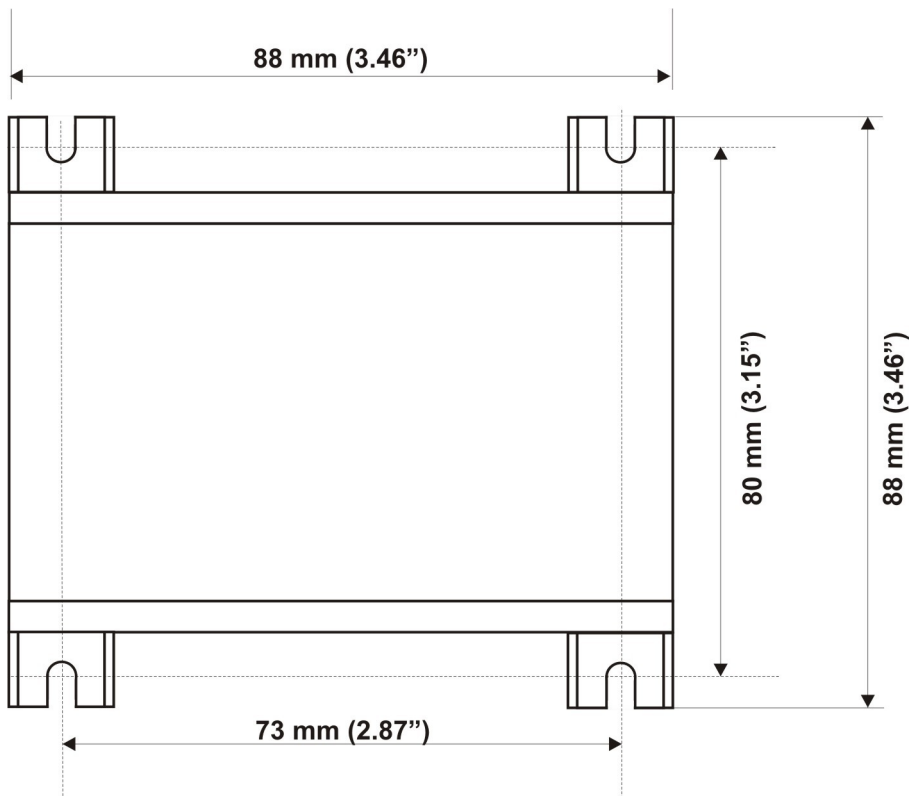
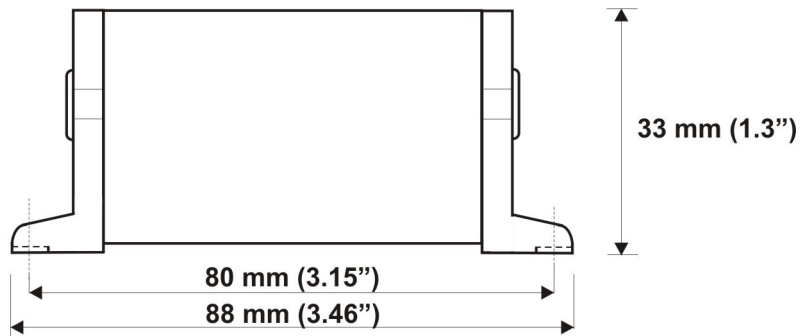
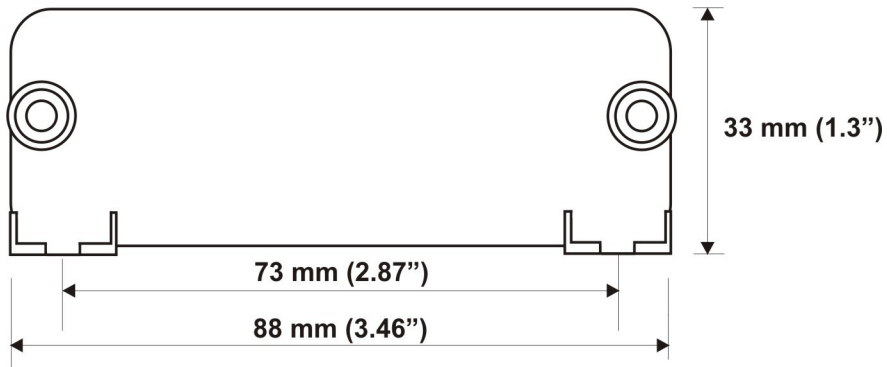

4 Installation

4.1 Cable Connections

Main connector (D9 connector: Unit Female, Cable Male)

D9 Pin	Color	Function
2	Blue	RS232 RXD Port 1 (Input)
5	Red	8-30Vdc (Power)
7	Brown	RS232 RXD Port 2 (Input)
9	Black	Ground

4.2 Status LEDs

3 LEDs provide status indication.

Green LED

Flashing: Receiving data
Off: Receiving no data

Orange LED

Flashing: Logging to SD card
Solid: SD card error / Write protect
Off: Not logging to SD card

Red LED

Flashing: Power / SD card Present
Solid: Power

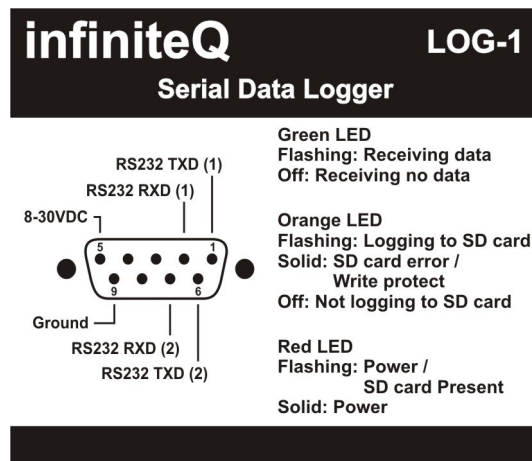

5 Setting the Data loggers Date & Time

There are 3 ways the data logger can set its internal clock.

Method 1:

The LOG-1 date and time will automatically be set if the received data has the date and time field. The Blaze EMS-2 / INFO-2 / FLIGHT-3 and Vega EMS-1 / INFO-1 will automatically set the time.

Method 2:

The date and time can be set from a file on the SD card called time.txt. This file must be in the root directory and will be read on power up. The file must be deleted once the date and time has been accepted as consecutive power ups will continually set the clock to the time in the file. The format of the data in the time.txt file is as follows:
dd/mm/yyyy hh:mm:ss

Method 3:

The date and time can also be set from the internal GPS (LOG-2 unit only).

6 Output File Format (Comma Separated Values (.CSV))

The LOG-1 will create a Comma Separated Values (.csv) file with the date as the filename. A new file is created every time the date changes. The file is created in the root directory of the SD card.

6.1 Message type 1 (Blaze EMS-2 / Vega EMS-1)

Message Type: 1

Date & Time:

Hobbs Minutes: Hobbs time in minutes

Maintenance Time: Maintenance time in hours

Volts: Volts in V

RPM 1: RPM 1 value

RPM 1 (%): RPM 1 value in percentage

RPM 2: RPM 2 value

RPM 2 (%): RPM 2 value in percentage

Analog Channel 1 Type:

- 0=Off
- 1=Pressure
- 2=Temperature
- 3=Current
- 4=Fuel Level

Analog Channel 1:

- Pressure in psi
- Temperature in Degrees C
- Current in A
- Fuel Level in Liters

Analog Channel 2 Type:

- 0=Off
- 1=Pressure
- 2=Temperature
- 3=Current
- 4=Fuel Level

Analog Channel 2:

- Pressure in psi
- Temperature in Degrees C
- Current in 0A
- Fuel Level in Liters

Analog 3 Channel Type:

- 0=Off
- 1=Pressure

2=Temperature

3=Current

4=Fuel Level

Analog Channel 3: Pressure in psi
 Temperature in Degrees C
 Current in A
 Fuel Level in Liters

Analog Channel 4 Type:

0=Off

1=Pressure

2=Temperature

3=Current

4=Fuel Level

Analog Channel 4: Pressure in psi
 Temperature in Degrees C
 Current in A
 Fuel Level in Liters

Manifold Pressure: Manifold pressure in mBar

Current: Current in A

CJC: Cold junction temperature in Degrees Celsius

TC1: Thermocouple channel 1 in Degrees Celsius

TC2: Thermocouple channel 2 in Degrees Celsius

TC3: Thermocouple channel 3 in Degrees Celsius

TC4: Thermocouple channel 4 in Degrees Celsius

TC5: Thermocouple channel 5 in Degrees Celsius

TC6: Thermocouple channel 6 in Degrees Celsius

TC7: Thermocouple channel 7 in Degrees Celsius

TC8: Thermocouple channel 8 in Degrees Celsius

TC9: Thermocouple channel 9 in Degrees Celsius

TC10: Thermocouple channel 10 in Degrees Celsius

TC11: Thermocouple channel 11 in Degrees Celsius

TC12: Thermocouple channel 12 in Degrees Celsius

Fuel flow: Fuel Flow in Liters per Hour

Example CSV data:

```
1,11/05/2020,11:01:39,423,2,13.4,1000,16,1000,16,1,5.4,2,54,3,10.2,2,23,1013,10.3,20,689,699,679,700,702,685,134,15
5,150,145,140,160,51.4
```

6.2 Message type 2 (Blaze TC-5 / Vega TC-4)

Message Type: 2
Date & Time:
CJC: Cold junction temperature in Degrees Celsius
TC1: Thermocouple channel 1 in Degrees Celsius
TC2: Thermocouple channel 2 in Degrees Celsius
TC3: Thermocouple channel 3 in Degrees Celsius
TC4: Thermocouple channel 4 in Degrees Celsius

Example CSV data:

```
2,11/05/2020,09:15:25,21,678,700,145,160
```

6.3 Message type 3 (Blaze INFO-2 / Vega INFO-1)

Message Type: 3
Date & Time:
G-Force: G-Force in G
Volts: Volts in V
Current: Current in A
OAT: OAT temperature in Degrees Celsius

Example CSV data:

```
3,11/05/2020,09:11:06,1.0,13.2,3.4,24
```

6.4 Message type 4 (Blaze TC-6)

Message Type:	4
Date & Time:	
CJC:	Cold junction temperature in Degrees Celsius
TC1:	Thermocouple channel 1 in Degrees Celsius
TC2:	Thermocouple channel 2 in Degrees Celsius
TC3:	Thermocouple channel 3 in Degrees Celsius
TC4:	Thermocouple channel 4 in Degrees Celsius
TC5:	Thermocouple channel 5 in Degrees Celsius
TC6:	Thermocouple channel 6 in Degrees Celsius
TC7:	Thermocouple channel 7 in Degrees Celsius
TC8:	Thermocouple channel 8 in Degrees Celsius
TC9:	Thermocouple channel 9 in Degrees Celsius
TC10:	Thermocouple channel 10 in Degrees Celsius
TC11:	Thermocouple channel 11 in Degrees Celsius
TC12:	Thermocouple channel 12 in Degrees Celsius

Example CSV data:

```
4,11/05/2020,09:11:06,20,689,699,679,700,702,685,134,155,150,145,140,160
```

6.5 Message type 5 (Blaze ALT-6 / Vega ALT-5)

Message Type:	5
Date & Time:	
Altitude:	Altitude in feet (Referenced to 1013.25mB)
Vertical Speed:	Vertical Speed in ft/min

Example CSV data:

```
5,11/05/2020,11:01:39,1302,121
```

6.6 Message type 6 (Blaze ASV-2 / Vega ASV-1)

Message Type: 6
Date & Time:
Altitude: Altitude in feet (Referenced to 1013.25mB)
Vertical Speed: Vertical Speed in ft/min
Airspeed: Airspeed in mph

Example CSV data:

```
6,11/05/2020,11:01:39,1302,121,78
```

6.7 Message type 7 (Blaze ASI-5 / Vega ASI-4)

Message Type: 7
Date & Time:
Airspeed: Airspeed in mph

Example CSV data:

```
7,11/05/2020,11:01:39,87
```

6.8 Message type 8 (Blaze TP-4 / Vega TP-3)

Message Type: 8

Date & Time:

Analog Channel 1 Type:

0=Off

1=Pressure

2=Temperature

3=Current

5=Volts

Analog Channel 1: Pressure in psi

Temperature in Degrees C

Current in A

Volts in V

Analog Channel 2 Type:

0=Off

1=Pressure

2=Temperature

3=Current

5=Volts

Analog Channel 2: Pressure in psi

Temperature in Degrees C

Current in A

Volts in V

Analog Channel 3 Type:

0=Off

1=Pressure

2=Temperature

3=Current

5=Volts

Analog Channel 3: Pressure in psi

Temperature in Degrees C

Current in A

Volts in V

Analog Channel 4 Type:

0=Off

1=Pressure

2=Temperature

3=Current

5=Volts

Analog Channel 4: Pressure in psi
 Temperature in Degrees C
 Current in A
 Volts in V

Example CSV data:

8,11/05/2020,11:01:39,1,5.4,2,54,3,10.2,5,13.7

6.9 Message type 9 (Blaze RPM-2 / Vega RPM-1)

Message Type: 9
Date & Time:
Hobbs Minutes: Hobbs time in minutes
Maintenance Time: Maintenance time in hours
RPM 1: RPM 1 value
RPM 1 (%): RPM 1 value in percentage
RPM 2: RPM 2 value
RPM 2 (%): RPM 2 value in percentage

Example CSV data:

9,11/05/2020,11:01:39,423,2,1000,16,1000,16

6.10 Message type 10 (Blaze MAP-4 / Vega MAP-3)

Message Type: 10
Date & Time:
Hobbs Minutes: Hobbs time in minutes
Maintenance Time: Maintenance time in hours
RPM: RPM value
RPM (%): RPM value in percentage
Manifold Pressure: Manifold pressure in mBar
Temperature: Temperature in Degrees Celsius

Example CSV data:

10,11/05/2020,11:01:39,423,2,1000,16,1040,21

6.11 Message type 11 (Blaze FF-5 / Vega FF-4)

Message Type:	11
Date & Time:	
Fuel Flow 1:	Fuel Flow 1 in Liters per Hour
Fuel Flow 2:	Fuel Flow 2 in Liters per Hour
Fuel Level 1:	Fuel Level 1 in Liters
Fuel Level 2:	Fuel Level 2 in Liters
Fuel Pressure:	Fuel pressure in psi

Example CSV data:

11,11/05/2020,06:37:51,5.4,6.5,34,40,4.5

6.12 Message type 12 (Blaze AHRS-2/4 MAG-2 / Vega AHRS-1/3 MAG-1)

Message Type:	12
Date & Time:	
Bank Angle:	Bank Angle in degrees
Pitch angle:	Pitch Angle in degrees
Yaw Angle:	Yaw Angle in 0.1 degrees
Slip:	Slip Center=0, Slip left=-50, Slip Right=50
Attitude Status:	bit 2 set = AHRS overrange
Heading:	Heading in degrees
G-Force:	G-Force in g

Example CSV data:

12,11/05/2020,06:37:51,1.0,6.2,2.0,24,0,23.4,1.0

6.13 Message type 13 (Blaze Flight-3)

Message Type:	13
Date & Time:	
Hobbs Minutes:	Hobbs time in minutes
Maintenance Time:	Maintenance time in hours
Altitude:	Altitude in feet (Referenced to 1013.25mB)
Vertical Speed:	Vertical Speed in ft/min
Airspeed:	Airspeed in mph
RPM:	RPM value
RPM (%):	RPM value in percentage
Fuel Flow:	Fuel Flow in Liters per Hour
Fuel Level:	Fuel Level in Liters
Volts:	Volts in V
Current:	Current in A
OAT:	OAT temperature in Degrees Celsius

Example CSV data:

```
13,11/05/2020,11:01:39,423,2,319,1450,84,1000,16,5.7,55,13.9,8.9,21
```

7 Warranty

This product carries a warranty for a period of one year from date of purchase against faulty workmanship or defective materials, provided there is no evidence that the unit has been mishandled or misused. Warranty is limited to the replacement of faulty components and includes the cost of labor. Shipping costs are for the account of the purchaser.

Note: Product warranty excludes damages caused by unprotected, unsuitable or incorrectly wired electrical supplies and or sensors, and damage caused by inductive loads.

8 Disclaimer

Operation of this instrument is the sole responsibility of the purchaser of the unit. The user must make themselves familiar with the operation of this instrument and the effect of any possible failure or malfunction.

This instrument is not certified by the FAA. Fitting of this instrument to certified aircraft is subject to the rules and conditions pertaining to such in your country. Please check with your local aviation authorities if in doubt. This instrument is intended for ultralight, microlight, home built and experimental aircraft. Operation of this instrument is the sole responsibility of the pilot in command (PIC) of the aircraft. This person must be proficient and carry a valid and relevant pilot's license. This person has to make themselves familiar with the operation of this instrument and the effect of any possible failure or malfunction. Under no circumstances does the manufacturer condone usage of this instrument for IFR flights.

IMPORTANT NOTICE:

You must make your own determination if the products sold by MGL Avionics are safe and effective for your intended applications. MGL Avionics makes no representations or warranties as to either the suitability of any of the products we sell as to your particular application or the compatibility of any of the products we sell with other products you may buy from us or anywhere else, and we disclaim any warranties or representations that may otherwise arise by law. Also, we offer no specific advice on how to install any of the products we sell other than passing along anything that may have been provided to us by the manufacturer or other issues. If you are in need of further information or guidance, please turn to the manufacturer, FAA Advisory Circulars and guidance materials, the Experimental Aircraft Association, or other reputable sources.

Continuing development sometimes necessitates specification changes without notice.

Instruments in the *Stratomaster Blaze* series

AHRS-2	Artificial Horizon and Magnetic Compass Indicator
AHRS-4	Self contained Artificial Horizon and Magnetic Compass Indicator
ALT-6	Altimeter and Vertical Speed Indicator (VSI)
ALT-7	Altimeter and Vertical Speed Indicator (VSI) with a transponder compatible RS232 & parallel Gillham code output
ASI-5	Airspeed Indicator (ASI)
ASI-5HS	Airspeed Indicator (ASI High Speed)
ASV-2	Altimeter, Airspeed (ASI) and Vertical Speed Indicator (VSI)
ASV-2HS	Altimeter, Airspeed (ASI High Speed) and Vertical Speed Indicator (VSI)
EMS-2	Engine Monitoring System
FF-5	Fuel Computer
FLIGHT-3	Primary Flight Instrument
FLIGHT-3HS	Primary Flight Instrument with High Speed ASI
INFO-2	Information Display (G-Force meter, UTC and Local Time, Slip Indicator, Outside Air Temperature (OAT), Battery Voltage, Current and charge display, Flight Timer & Flight Log, Stopwatch, Countdown Timer and Alarm)
MAG-2	Magnetic Compass Indicator
MAP-4	Manifold Pressure and RPM Indicator
RPM-2	Universal Engine / Rotor RPM Indicator
TC-5	4 Channel Thermocouple (EGT/CHT) Indicator
TC-6	12 Channel Thermocouple (EGT/CHT) Indicator
TP-4	4 Channel Universal Analog Input (Pressure/Temperature/Current/Volts) Indicator

Instruments in the *Stratomaster Vega* series

AHRS-1	Artificial Horizon and Magnetic Compass Indicator
AHRS-3	Self contained Artificial Horizon and Magnetic Compass Indicator
ALT-5	Altimeter and Vertical Speed Indicator (VSI)
ASI-4	Airspeed Indicator (ASI)
ASI-4HS	Airspeed Indicator (ASI High Speed)
ASV-1	Altimeter, Airspeed (ASI) and Vertical Speed Indicator (VSI)
ASV-1HS	Altimeter, Airspeed (ASI High Speed) and Vertical Speed Indicator (VSI)
EMS-1	Engine Monitoring System
FF-4	Fuel Computer
INFO-1	Information Display (G-Force meter, UTC and Local Time, Slip Indicator, Outside Air Temperature (OAT), Battery Voltage, Current and charge display, Flight Timer & Flight Log, Stopwatch, Countdown Timer and Alarm)
MAG-1	Magnetic Compass Indicator
MAP-3	Manifold Pressure and RPM Indicator
RPM-1	Universal Engine / Rotor RPM Indicator
TC-4	4 Channel Thermocouple (EGT/CHT) Indicator
TP-3	4 Channel Universal Analog Input (Pressure/Temperature/Current/Volts) Indicator