

Table of Contents

FCC Statement.....	3
General.....	3
Document history.....	3
Description.....	3
The Receiver	3
Power supply.....	4
Antenna.....	4
Digital control interfaces.....	4
Applicable standards.....	5
Specification table.....	5
General specifications.....	5
Audio input specifications.....	6
Audio output specifications.....	6
Audio and RX filters.....	6
Navigation receiver performance.....	7
Environmental qualification matrix.....	7
N16 Connector pinout.....	10
Typical connection diagrams.....	11
Audio wiring.....	11
Audio signal wiring advice.....	11
Control heads and options.....	12
Pinout for 3.18" Razor and 2.25" Vega transceiver control head.....	12
N16 with one or more control heads.....	13
N16 with a MGL Avionics EFIS system.....	13
V16 plus N16 Navigation receiver.....	13
V16 plus N16 with one or more control heads.....	13
RS232 and CAN bus communication protocols.....	14
Setup menu.....	14
Menu items.....	14
Mechanical dimensions.....	16
Materials	16

FCC Statement

THIS DEVICE COMPLIES WITH PART 15 OF THE FCC RULES. OPERATION IS SUBJECT TO THE FOLLOWING TWO CONDITIONS: (1) THIS DEVICE MAY NOT CAUSE HARMFUL INTERFERENCE, AND (2) THIS DEVICE MUST ACCEPT ANY INTERFERENCE RECEIVED, INCLUDING INTERFERENCE THAT MAY CAUSE UNDESIRE OPERATION. FCC ID: **2ANEFN16**

NOTE: THE **GRANTEE** IS NOT RESPONSIBLE FOR ANY CHANGES OR MODIFICATIONS NOT EXPRESSLY APPROVED BY THE PARTY RESPONSIBLE FOR COMPLIANCE. SUCH MODIFICATIONS COULD VOID THE USER'S AUTHORITY TO OPERATE THE EQUIPMENT.

General

This manual documents the installation and use of the N16 VHF navigation receiver. Please note that operation of the transceiver with respect to settings such as frequency, volume etc is done by the connected control panel. User interface varies by type of connected system. Please refer to documentation for the connected equipment for details.

This manual describes available settings through the connected equipment in a generic way that is applicable to all types.

Document history

2 March 2018, first release.

Description

The N16 navigation receiver is a split module consisting out of the receiver body and external control. External control can take the form of one or more panel mount control heads and/or control by an EFIS system.

The N16 is designed to be able to monitor one or two navigation frequencies.

In case of two stations, they can be assigned in any order to either two VOR or one VOR and one ILS with both localizer and glide slope.

The N16 can also be combined with the V16 airband transceiver to form a NAVCOM solution.

The Receiver

The receiver is implemented as a direct conversion architecture. The signal to be received is converted directly to audio baseband using a dual receiver chain with two identical receivers. One of these produces a slightly delayed signal. These signals are known as I and Q. They are then converted into digital using very high quality 24 bit converters and all further signal processing takes place in a high performance processor. Here the original carrier is recreated from the I/Q signals and following extensive processing the audio and navigation signals are recovered from the carrier while unwanted signals are rejected.

In order to meet latest ICAO requirements for FM band immunity the receiver employs a

surface acoustic wave RF filter before any active amplification to reject any out of band signals before they can inter-modulate with wanted signals. The overall receiver architecture is designed to be able to handle very strong in band and out of band signals while managing at the same time to provide good sensitivity to very weak signals.

The Receiver can be operated in scanning mode. In this mode both primary and secondary frequencies are monitored.

This is done in a time multiplex fashion with the receiver equally split to monitor both frequencies.

With scanning switched off, the receiver monitors the primary frequency and the secondary frequency is inactive. The frequency can be tuned to either a VOR or a localizer. In case of a localizer the paired glide slope frequency is also monitored.

Received audio is available through two filters – one is a narrow 1020Hz filter for the morse ID while the other provides the voice band excluding the 1020Hz part of the band which is suppressed by a matching notch filter. The output of both filters can be combined to allow the full audio voice band.

In case either filter is off the corresponding signal is still routed through but attenuated by 20db (a factor of 10).

A morse code decoder is enabled on the 1020 Hz ID signal. The decoder can adapt to a wide variety of morse word rates and repetition rates and generally is able to decode the ID of a station with a reasonably interference free signal. The result of the decoding is sent to the connected control device for optional display.

Power supply

The N16 navigation receiver is designed to be operated on a typical 12V DC aircraft power system. The DC supply must be free of undesired transients and reasonably stable within the acceptable supply voltage range of the N16.

It is possible to operate the N16 on 24/28V DC power supplies as well.

For operation with compromised power sources on aircraft it is advised to consider external power conditioning such as the MGL Avionics AvioGuard isolated power supply.

Antenna

The N16 navigation receiver is designed to operate with standard 50 ohm impedance aircraft VHF navigation antennas that also allow glide slope frequency band reception.

The modular nature of the N16 allows placement of the N16 closer to the antenna, reducing antenna cable length and losses.

The antenna connector provides a DC isolated path to the antenna. This includes the cable sheath. This means there is no possibility of a DC current path from aircraft skin via antenna and cable through the radio. This protects the radio against ground faults and prevents ground loops.

Digital control interfaces

The N16 navigation radio provides two RS232 ports as well as a CAN bus interface.

The CAN bus is typically used with control heads from MGL Avionics.

RS232 port 1 may be used with MGL EFIS systems. RS232 port 2 is not currently used.

Applicable standards

The N16 navigation receiver meets or improves on the following standards:

ETSO 2C34f, ETSO 2C36f, ETSO 2C40c

TSO C34e, TSO C36e, TSO C40e

FCC Part 15 radiated emissions

With reference to:

ICAO Annex 10 as amended.

Specification table

General specifications

Compliance	ETSO 2C34f, ETSO 2C36f, ETSO 2C40c, TSO C34e, TSO C36e, TSO C40e
FCC Identification	2ANEFN16
Documents	DO160G, DO192, ED47B, DO195, ED46B, DO196, ED22B
Software	Software ED-12B RTCA DO-178C Level C
Supply voltage	10-28VDC, DO-160 surge limiter active at 34V and higher.
Supply current	RX: 0.2A at 13.8V
Operating temperature	-20 to +55 degrees Celsius. Convection or forced air cooling recommended if operated regularly at high ambient temperatures.
Frequency range	108.000 MHz to 117.950 MHz, 50Khz channel spacing (VOR, localizer) 329.150 MHz to 335.000 Mhz, 50Khz channel spacing (Glide slope)
RX sensitivity	-107dbm @ 127Mhz for +6db S+N/N, 30% modulation, 1Khz, (0.3-2.9Khz bandwidth)
RX Large signal	+9dbm @127Mhz, off-channel blockers >+15dbm
RX audio unwanted signals including distortion products	Less than -50db referred to 30% modulated carrier typical up to large signal limit.
Adjacent channel suppression	>80db typical
LO leakage into antenna	<-100dbm

connector	
RX bandwidths	+/-24Khz @ 50Khz spacing
RX Squelch	Manual level with automatic adjustment within fixed range of manual setting. Adjustment range: Off + -100dbm to -70dbm in 32 steps.
Digital audio	I/Q sampling: 24 bits @ 48Khz, Audio: 24Bits @ 24Khz
Weights	300 grams, complete unit. 120 grams, functional PCB with shielding plate excluding housing (as OEM module for integration into third party systems)
Dimensions	Mounted height 31mm Width 88mm Depth (including flanges) 167mm Depth (excluding flanges) 142mm

Audio input specifications

Auxiliary input	Gain range -15db to +6db	Maximum input level 2Vpp Typical level required for normal volume at +6db is 100mVpp. Input impedance 47KOhm.
-----------------	--------------------------	---

Audio output specifications

Output impedance	8 ohms. Suitable for connection of high impedance headphones.
Output power	0.2W low distortion. Up to 0.5W at 1% distortion.
Maximum voltage swing	5Vpp (1W into 8 ohms) 6.5Vpp into 300 ohms
Typical voltage swing for 600 ohm aviation headsets	1Vpp-2Vpp
Frequency response audio power amplifier	200Hz to 20Khz at 8 ohms load, lower limit decreases with lower loading (100uF output coupling capacitor)
Volume control range	32 steps of 3db each. Total control range = 96db.

Audio and RX filters

AGC	0-5Hz, Bessel 4 pole LP, step response 0.1 second to 95% of final value.
RX audio 50Khz	200-2900Hz, Butterworth 4 pole BP
Channel filter	3 pole R/C LP at ~18Khz
RX anti aliasing	24Khz FIR > 60db stop band (adds to

	channel filtering)
--	--------------------

Navigation receiver performance

VOR minimum signal for a radial error of less than 1 degree (note: signal will be flagged)	-100dbm
VOR maximum signal level for 1 degree error.	+10dbm
VOR radial error @ -89dbm	+/- 0.1 degrees
VOR radial error @ -60dbm	+/- 0.05 degrees
VOR flag level	-98dbm
VOR error addition in scanning mode	+/- 0.1 degrees
Localizer flag level	-98dbm
Localizer DDM error band at -100dbm (note: signal will be flagged)	+/- 10% of full scale
Localizer DDM error band at -89dbm	+/- 2% of full scale
Glide slope flag level	-90dbm
Glide slope DDM error band at -80dbm	+/- 2% of full scale

Environmental qualification matrix

The environmental qualification is based on the document DO-160G

Temperature and Altitude	4.0	Equipment Categories B2, C1	
Low temperature ground survival	4.5.1	-50°C	
Low temperature shorttime operating	4.5.1	-30°C	
Low temperature operating	4.5.2	-20°C	
High temperature operating	4.5.4	+55°C	
High temperature shorttime operating	4.5.3	+65°C	
High temperature ground survival	4.5.3	+85°C	

Loss of Cooling	4.5.5	Cooling air not required	Convection cooling or forced air cooling recommended in compromised installations.
Altitude	4.6.1	55,000 feet	
Decompression	4.6.2	8,000 to 55,000 feet in 15 seconds	
Over pressure	4.6.3	-15,000 feet	
Temperature Variation	5.0	Equipment Category B	
Humidity	6.0	Equipment Category A	
Operational Shocks	7.2	Equipment Category B	
Crash Safety	7.3	Equipment Category B Type 5	
Vibration	8.0	Aircraft zone 2; type 3, 4, 5 to category S level M, type 1 (Helicopters) to category U level G	
Explosion	9.0	Equipment identified as Category X – no test required	
Waterproofness	10.0	Equipment identified as Category X – no test required	
Fluids Susceptibility	11.0	Equipment identified as Category X – no test required	
Sand and Dust	12.0	Equipment identified as Category X – no test required	
Fungus	13.0	Equipment identified as Category X – no test required	
Salt Spray	14.0	Equipment identified as Category X – no test required	
Magnetic Effect	15.0	Equipment tested to Category Z, safe distance 20cm	
Power Input	16.0	Equipment Category BXX	
Voltage Spike	17.0	Equipment Category B	
Audio frequency conducted	18.0	Equipment Category B	

susceptibility			
Induced signal susceptibility	19.0	Equipment Category AC	
Radio frequency susceptibility	20.0	Equipment Category TT	
Radio frequency emission	21.0	Equipment Category B	
Lightning induced transient susceptibility	22.0	Equipment identified as Category B2G2L2 – no test required	
Lightning direct effects	23.0	Equipment identified as Category X – no test required	
Icing	24.0	Equipment identified as Category X – no test required	
Electrostatic Discharge	25.0	Equipment identified as Category X – no test required	
Fire, Flammability	26.0	Equipment identified as Category C	

Notes: Power input tests chapter 16. The N16 easily complies with all required criteria. The N16 has a limitation related to power supply voltage rise time which falls well outside of any required performance standards. Voltage rises from 0 to about 2.0V at any rate and then the rise time to about 3.6V is very slow (in the region of greater than about 0.5 seconds) the N16 will enter self protection mode which will only be released when voltage drops again below 2.0V. In this mode the internal processor will lock itself and its integrated memories out for protection against damage by pre-start brownout conditions. This limitation does not apply if the N16 is already up and running and voltage dips not lower than 2.0V before rising again slowly as the critical startup time does not apply in this case due to a secondary brownout detection being active at this time.

The processor, should it enter self protection mode, will release this mode on the next power cycle provided voltage ramp up is faster than the maximum time of 0.5 seconds in the mentioned voltage range.

This limitation however is unlikely to affect any real world applications and is mentioned only for completeness sake.

The N16 is designed not to commence operation until supply voltage reaches about 7V on startup regardless of the above condition. Once operating, the N16 will continue to operate in receive mode down to about 6V.

The above measures have been included to prevent any internal hardware damage due to unusual supply voltage conditions during low to very low voltage conditions.

N16 Connector pinout

1	Headphone audio (speaker output). Suitable for connection of multiple 600 ohm aviation headsets or a 8 ohm impedance (minimum) speaker.
2	audio output ground
3	CAN-H Communications interface to a compatible MGL control head
4	CAN-L As above
5	RS232 RX 1 Communications interface to an MGL EFIS system
6	RS232 TX 1 As above
7	RS232 RX 2 Not used, do not connect
8	RS232 TX 2 Not used, do not connect
9	Audio input ground
10	
11	Audio input ground
12	
13	Audio input ground
14	
15	
16	
17	
18	
19	Auxiliary audio ground
20	Auxiliary audio input (Music, EFIS, mobile phone etc)
21	Programming pin. Leave this pin unconnected
22	Power supply ground
23	Power supply ground (connected internally to pin 22)
24	+12V to +28V DC power supply input
25	+12V to +28V DC power supply input (connected internally to pin 24)

Typical connection diagrams

Audio wiring

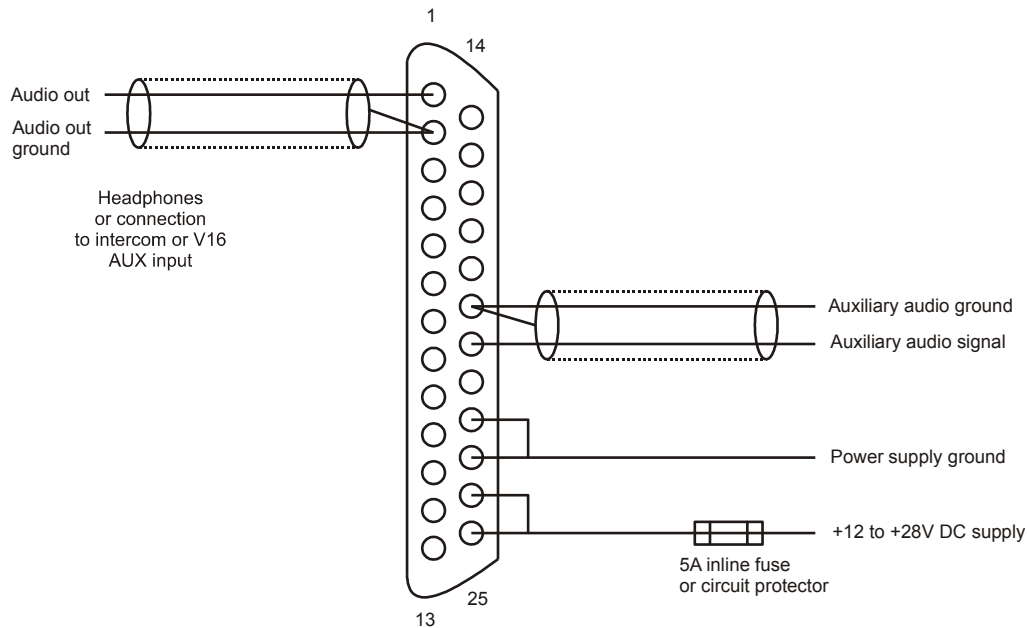

The audio output may be wired to a headset, speaker or an audio input of a suitable intercom. It may also be wired to the AUX input of a V16 transceiver to form a combined NAV/COM. In this case the AUX input of the N16 becomes the AUX input of the combined NAV/COM system.

Audio signal wiring advice

It is strongly advised to use good quality shielded audio cable. The diagram shows that all shields are connected on **only one side**. Shields are never used to conduct signals.

Signal grounds have their own wire inside the shielded cable (you would be using a two core plus shield cable).

NEVER run the audio output signals together with the microphone signals inside the same shielded cable. This may result in feedback effects.

Avoid running any audio cable next to cables that may contain interference signals. It is good wiring practice to run audio cables in their own bundles.

Never run any cables (audio, signal or otherwise) close to the antenna cable.

If using audio and microphone sockets please ensure that these are electrically isolated from each other as well as from any conduction material such as a panel, metal box, bracket etc. If the sleeves are not isolated it is likely undesirable audio interference may occur.

Control heads and options

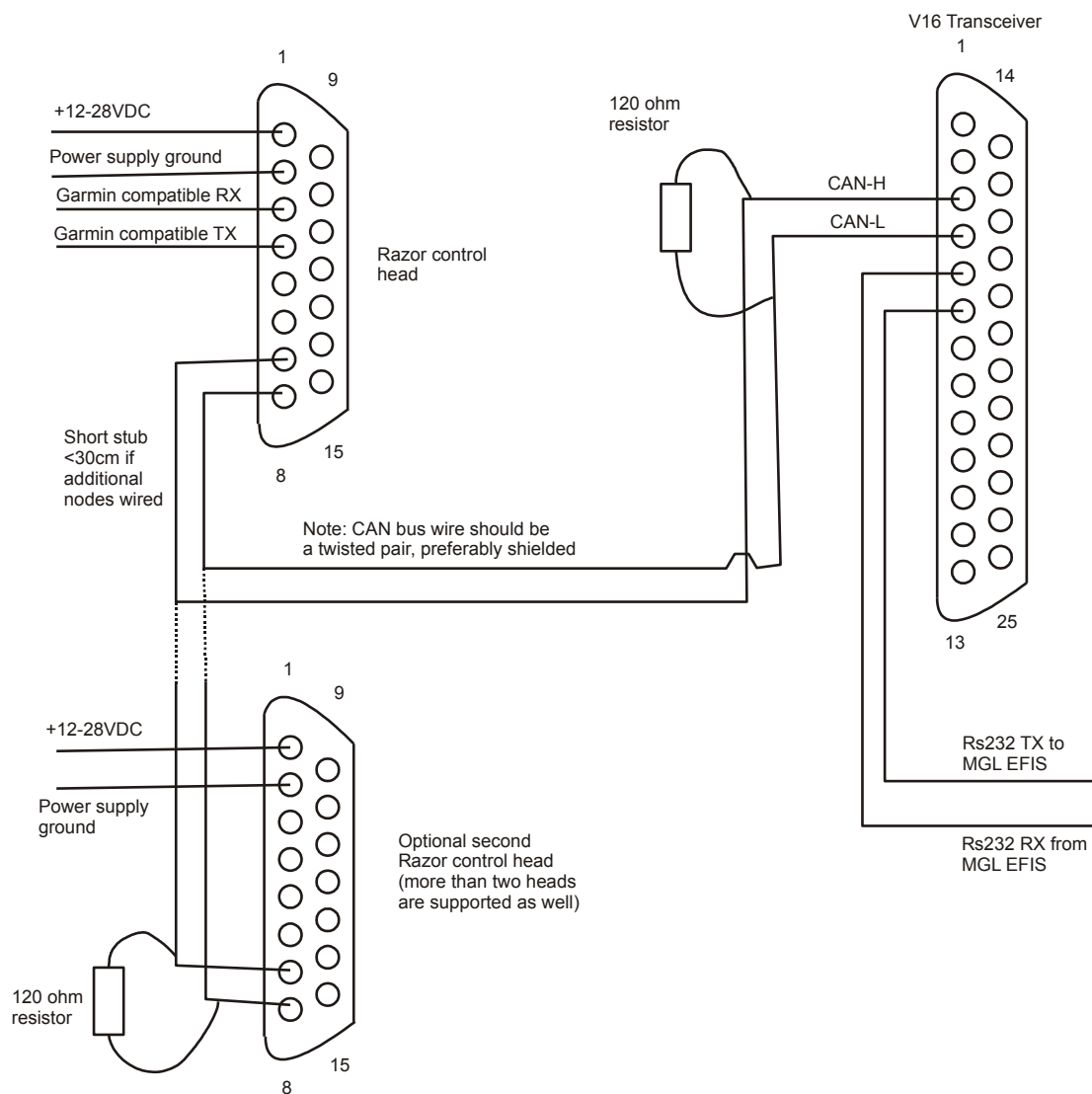

The N16 navigation receiver module must be connected to at least one controller or an MGL EFIS system.

Pinout for 3.18" Razor and 2.25" Vega transceiver control head

1	Supply +9 to +28VDC
2	Supply ground
3	RS232 RX Port 1
4	RS232 TX Port 1
5	RS232 RX Port 2
6	RS232 TX Port 2

7	CAN H (connect to CAN H on transceiver and NAV radio)
8	CAN L (connect to CAN L on transceiver and NAV radio)
9	Ground (Internally connected to pin 2)
10	KeepAlive. Do not connect.
11	A1. Control input. Select desired function in Razor setup menu.
12	A2. Control input. Select desired function in Razor setup menu.
13	Program pin. Do not connect.
14	USB P. Do not connect
15	USB M. Do not connect.

N16 with one or more control heads

Either a 3.18" or 2.25" head may be used. The head is connected to the N16 using the CAN bus.

The head provides a RS232 bus that implements Garmin compatible interface for use by third party systems.

Multiple control heads may be connected to the N16 if desired.

N16 with a MGL Avionics EFIS system

The N16 is connected via RS232 port number 1 to the chosen port on the EFIS. Configure the EFIS for a MGL COM radio (The MGL COM radio setting also accepts the N16 navigation receiver). Connect RX to TX and TX to RX. On the other end. Use of shielded cable is recommended. Do NOT connect a ground between N16 and EFIS if both are supplied from the same supply as this will create a ground loop that can invite interference.

Note: It is possible to connect a N16 to the EFIS and at the same time to one or more control heads via the CAN bus.

V16 plus N16 Navigation receiver

The V16 can be combined with a N16 navigation receiver that provides VOR, ILS and glideslope information.

Both V16 and N16 are connected via CAN bus and optionally to one or more control heads.

This effectively turns the V16 and N16 into a single NAV/COM solution.

The connection to an MGL EFIS remains on the V16 RS232 port number 1. In this case the information from the N16 received via CAN bus is forwarded to the EFIS on the same RS232 port.

V16 plus N16 with one or more control heads

If the V16 and N16 is connected via CAN bus to any control head, that heads RS232 port

number 1 acts as a Garmin NAV/COM compatible communications port.

Note: This also works if the V16 and N16 is connected to an MGL EFIS via the V16 RS232 port number one at the same time.

RS232 and CAN bus communication protocols

The protocols used to communicate with the N16 are available to third party developers that would like to integrate the N16 into their systems.

Please contact MGL Avionics (info@MGLAvionics.co.za) to obtain the latest protocol documentation.

Setup menu

The setup menu's exact visual form cannot be described here as it depends on the type of control system (Head or EFIS).

However in principle it is similar across all platforms and consists of a text created by the radio once the menu system has been activated.

The text represents one menu item which can either be selected or changed depending on its type.

The list here shows all the available menu items and typical texts you can expect and explains the settings.

Your controller will provide a means to activate the menu. Typically this would be pushing a button or some action on a touch screen or similar.

Menu items

Audio ID ON Audio ID OFF	Switches the 1020Hz ID filter on or off. With the filter off the morse ID is suppressed by 20db. Note: It is included here in the menu even though other means of control may be available.
Audio voice ON Audio voice OFF	Switches the audio voice band filter on or off. With the filter off the voice band is suppressed by 20db. Note: It is included here in the menu even though other means of control may be available.
Volume 0..31	The RX volume setting. Note: It is included here in the menu even though other means of control may be available.
Squelch 0..31	Receiver squelch. Note: It is included here in the menu even though other means of control may be available.
N16...	N16 type ID and firmware version. This is display

	only and cannot be changed.
Serial...	Manufacturers device serial number. This is display only and cannot be changed.
Factory default	Allows you to set all settings to factory default after confirming the choice.

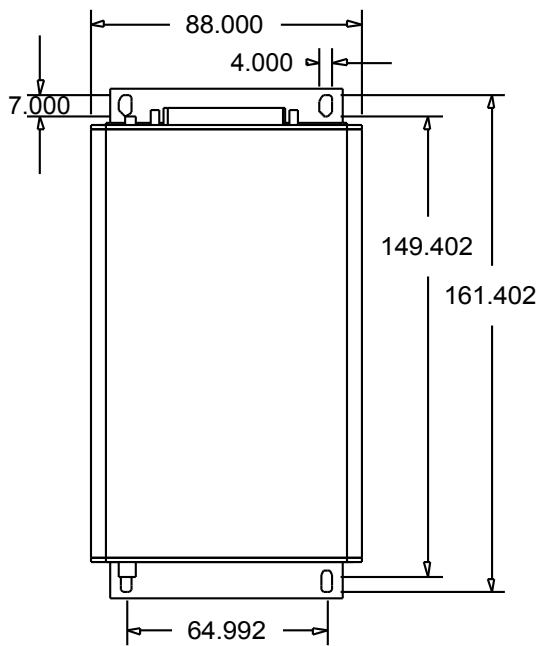

Dimensions +/- 0.25mm tolerance

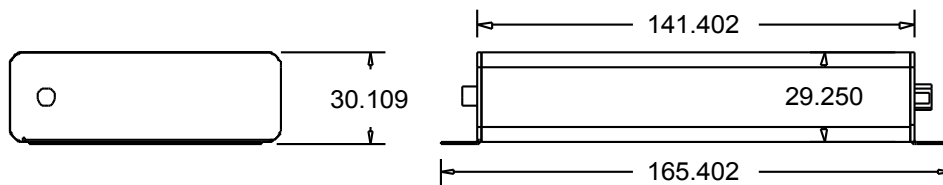

Mechanical dimensions

Materials

Body: Aluminum extrusion

Flanges: Stainless Steel, 1mm, Fasteners Stainless Steel.

Labels: Vinyl